



Il casellario Milano idoneo per ambienti interni o esterni riparati in quanto non ha la feritoia protetta dalla veletta basculante. A richiesta è possibile fornire lo sportello corredato da finestrelle di ispezione.

*Milano post office box is good for internal or external protected places, because its slit is not protected from a balancing flap. On demanding it's possible to provide its door with control window.*



> PARTICOLARE APERTURA | OPENING DETAIL



> FINESTRA DI ISPEZIONE | CHECK WINDOW

#### STRUTTURA

composta da tubolari e pannelli in alluminio trattato nelle parti in vista a norme UNI.

#### SPORTELLO

in profilato di alluminio nella finitura base senza finestre di ispezione con apertura basculante e feritoia libera per introduzione della corrispondenza, completo di portanome e targhetta accessibile solo dall'interno, serratura di sicurezza a cilindro con chiavi in doppia copia.

#### INSTALLAZIONE

sia da incasso muro con apposita cornice coprifuga che da appendere muro con apposite staffe interne.

#### DIMENSIONI

proposto in due formati a norme DIN porta-riviste oppure a richiesta su misura sia in Larghezza che Profondità.

#### STRUCTURE

*it is composed by solid aluminium tubulars and panels made respected UNI rules.*

#### DOOR

*aluminium bordered based finish, without windows control, with balancing flap and free slit to introduce mails. It's completed by nameplate accessible just from inside, security cylinder lock with double keys.*

#### INSTALLATION

*wall inserted with finishing frame - wall hanger with its own internal stirrup.*

#### SIZE

*it is proposed in 2 formats, magazine stand according to DIN rules - on demanding as you want (width - depth).*



> PROFONDITÀ 250 mm | DEPTH 250 mm

	370	740	1110	1480	1850	2220
133	1	11	21	31	41	51
266	2	12	22	32	42	52
399	3	13	23	33	43	53
532	4	14	24	34	44	54
665	5	15	25	35	45	55
798	6	16	26	36	46	56
931	7	17	27	37	47	57
1064	8	18	28	38	48	58
1197	9	19	29	39	49	59
1330	10	20	30	40	50	60

> INCASSO A MURO | BUILT TO WALL

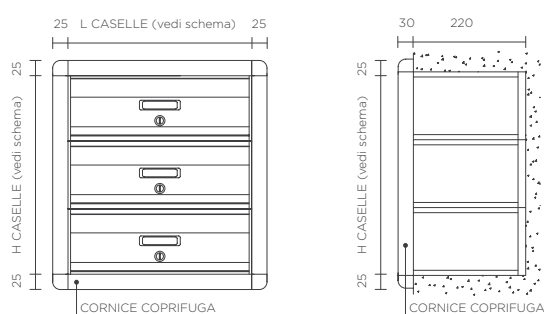

> PROFONDITÀ 350 mm | DEPTH 350 mm

	270	540	810	1080	1350	1620
133	1	11	21	31	41	51
266	2	12	22	32	42	52
399	3	13	23	33	43	53
532	4	14	24	34	44	54
665	5	15	25	35	45	55
798	6	16	26	36	46	56
931	7	17	27	37	47	57
1064	8	18	28	38	48	58
1197	9	19	29	39	49	59
1330	10	20	30	40	50	60

> SEMI INCASSO A MURO | SEMI-RECESSED WALL

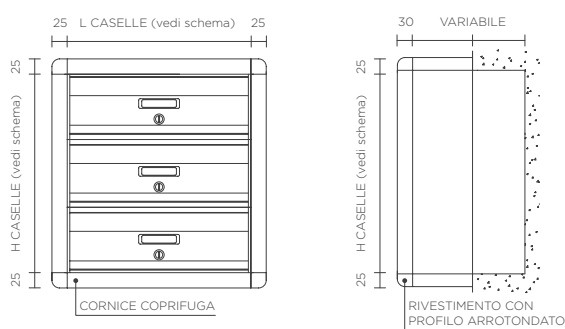

> INCASSO RECINZIONE | BUILT FENCE

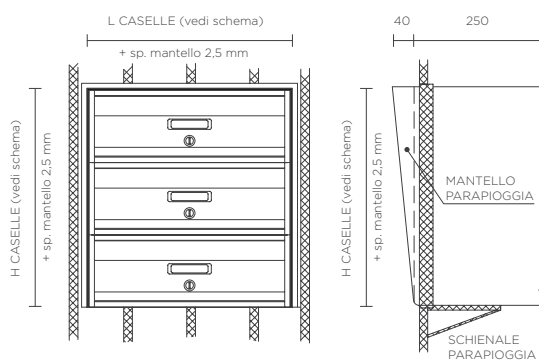

> APPENDERE A MURO | HANG ON THE WALL

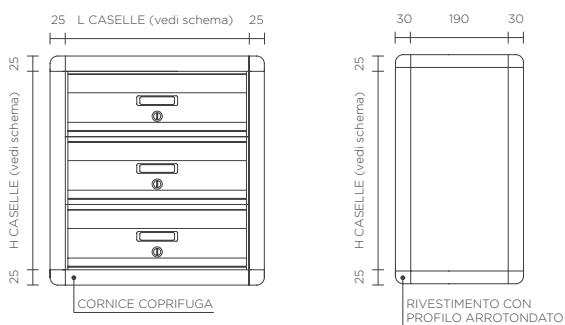

per caselle da appendere dotate di profilo arrotondato aggiungere 50 mm alle misure sopra indicate  
boxes to be hung with rounded profile add 50 mm to the above measures